

2025 年全港性系統評估(中學) 便覽

**Territory-wide System Assessment 2025
(Secondary Schools)
Quick Guide**

第四部分 Part 4

**數學科
Mathematics**

Part 4

Mathematics

Secondary 3

1. Scope of the Assessment

The Secondary 3 Assessment is based on the documents *Mathematics Education Key Learning Area Curriculum Guide (Primary 1 - Secondary 6)* (2017) and *Basic Competency Descriptors for Key Stage 3 Mathematics Curriculum*. It focuses on the basic and important areas of the Secondary 1 to 3 curriculum and assesses on the concepts, knowledge, skills and applications in these areas. It covers the three strands Number and Algebra, Measures, Shape & Space and Data Handling.

2. Format of the Assessment

The Assessment will be conducted in a paper-and-pencil mode. (Use of HKEAA approved calculators is allowed.) In order to cover adequately the areas to be assessed in Key Stage 3, a number of items will be set for the full paper of the Assessment. These will be divided into 4 sub-papers of 65 minutes each. Each student will be required to attempt one of the sub-papers only. There is no formula table in each paper for reference.

Each sub-paper will consist of some 40 items, covering the three strands Number and Algebra, Measures, Shape & Space and Data Handling. In the Assessment, various types of items will be used. Some are multiple-choice items which can be marked objectively. Some are open-ended items, in which students have to write their own answers, or write out the necessary mathematics expressions, conclusions and explanations.

Sub-paper	Sub-paper 1	Sub-paper 2	Sub-paper 3	Sub-paper 4
Strand				
Number and Algebra				
Measures, Shape & Space	65 minutes	65 minutes	65 minutes	65 minutes
Data Handling				

3. Exemplars

Some examples are shown below to illustrate the different types of items set. These examples are by no means exhaustive.

Number and Algebra Strand

1. $\frac{(a^2)^3}{a^5} =$

- A. 0.
- B. 1.
- C. a .
- D. a^3 .

2. Factorise $4x^2 - y^2$.

- A. $(2x - y)^2$
- B. $4(x + y)(x - y)$
- C. $(2x + y)(2x - y)$
- D. $(4x + y)(4x - y)$

3. The coefficient of x^2 in the polynomial $x^3 - x^2 + 4$ is

- A. -1.
- B. 0.
- C. 1.
- D. 2.

4. In Sunny Florist, the prices of a rose and a tulip are \$10 and \$7 respectively. Mary bought x roses and y tulips for \$74. The number of tulips that she bought was $\frac{1}{3}$ of that of roses.

Which of the following pairs of simultaneous equations shows the relationships between x and y ?

A.
$$\begin{cases} 7x + 10y = 74 \\ y = 3x \end{cases}$$

B.
$$\begin{cases} 7x + 10y = 74 \\ y = \frac{x}{3} \end{cases}$$

C.
$$\begin{cases} 10x + 7y = 74 \\ y = 3x \end{cases}$$

D.
$$\begin{cases} 10x + 7y = 74 \\ y = \frac{x}{3} \end{cases}$$

5. Which of the following is an identity?

A. $3x = 6$

B. $3x + 4x = 7x$

C. $3x - 2 = 2 - 3x$

D. $3(x + 1) = 3x + 1$

6. An electronic wallet uses directed numbers to represent receiving and paying money.

For example, -100 dollars represents a payment of 100 dollars.

Use a directed number to represent each of the following situations:

(i) Use the electronic wallet to receive 500 dollars.

(ii) Use the electronic wallet to pay 20 dollars.

7. Find the value of x in the following sequence of square numbers.

1, 4, 9, 16, 25, x , ...

8. Solve the inequality $7 - 3x \leq 1$.

9. A shop offers free delivery service for orders of \$600 or above. Mr Lee is going to buy 21 boxes of vitamin C. Each box of vitamin C costs \$32.

Based on the description above, give approximations for each of the **UNDERLINED VALUES** respectively. Hence, estimate the total amount that Mr Lee needs to pay for his purchase. Briefly explain whether he can enjoy free delivery service.

10. Jason deposits \$25 000 in a bank at an interest rate of 6% p.a. compounded yearly. Find the amount that he will receive after 2 years.

Measures, Shape and Space Strand

11. In the figure, $ABCD$ is a square. The coordinates of D are

- A. $(-1, 2)$.
- B. $(-1, -2)$.
- C. $(-4, 2)$.
- D. $(-4, -2)$.

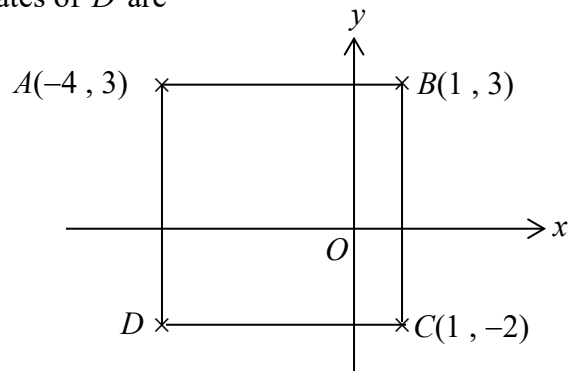

12. In the figure, $ABCD$ is a straight line. $BE \parallel CF$ and $\angle ABE = 40^\circ$. Find x .

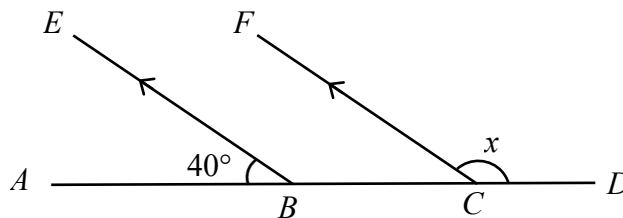

13. The figure shows the diagram of a right circular cylinder:

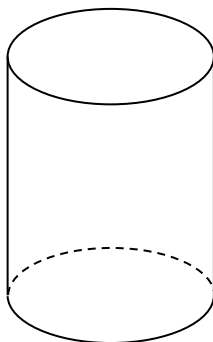

The figure below is the diagram of a **right circular cone**, with one missing line. Referring to the sketching shown above, complete the diagram.

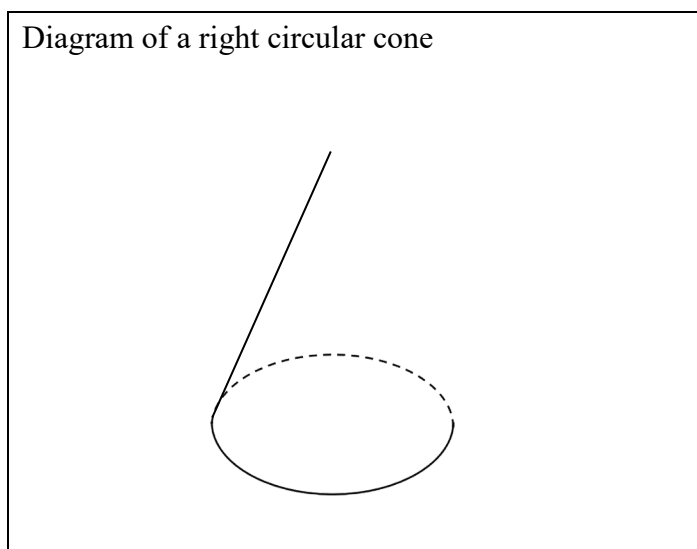

14. Mary is walking uphill along a road. After she has walked 40 m, she is 16 m vertically above the ground. Find θ .

- A. 21.8°
- B. 23.6°
- C. 66.4°
- D. 68.2°

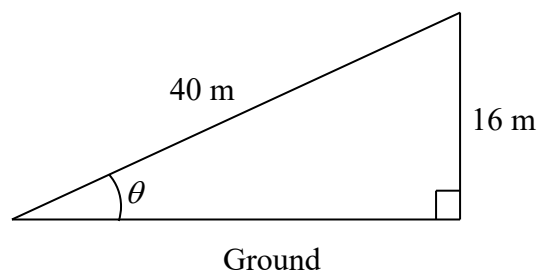

15. Which of the following represents the parallelogram as shown?

- A. P
- B. PQ
- C. $PQRS$
- D. $PQSR$

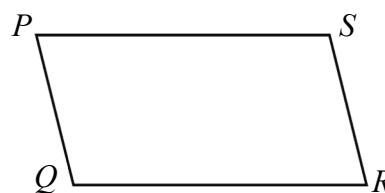

16. In the figure, $\triangle ABD \cong \triangle CBD$. Which of the following must be correct?

- A. $\angle ADB = \angle CBD$
- B. $\angle BAD = \angle BCD$
- C. $AB = CD$
- D. $AD = BC$

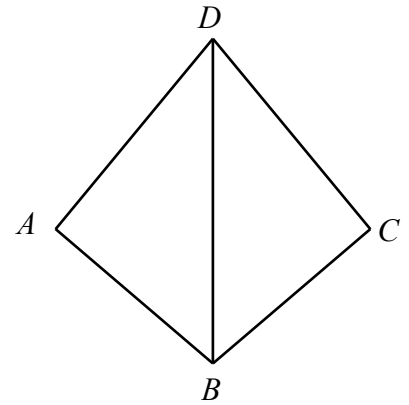

17. $P(5, -3)$ and $Q(2, 1)$ are two points in the rectangular coordinate plane. Find the distance between P and Q .

18. In the figure, find the value of x .

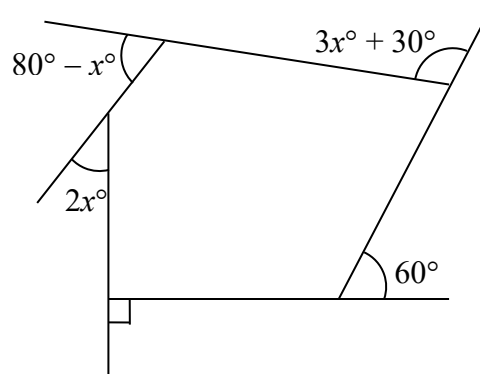

19. In the figure, AB , CD and EH are straight lines. $\angle EFB = \angle CGH = 70^\circ$. Prove that $AB \parallel CD$.

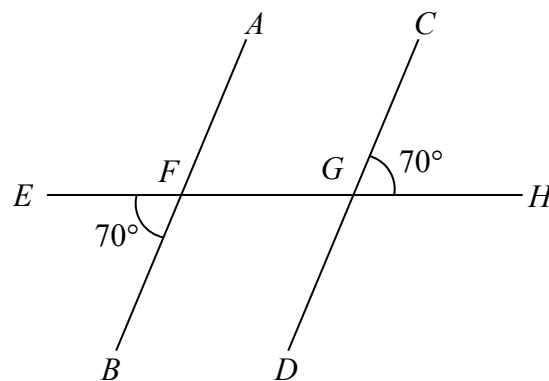

20. In the figure, the ice cream cones of regular size and mini size are similar solids. Their heights are 16 cm and 8 cm respectively. The curved surface area of the regular-sized one is 208 cm^2 . Find the curved surface area of the mini-sized one.

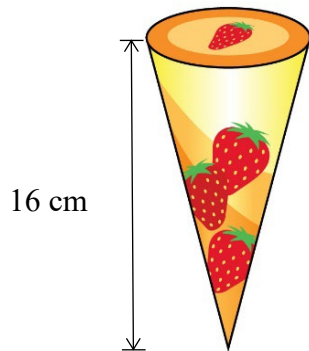

ice cream cone of regular size

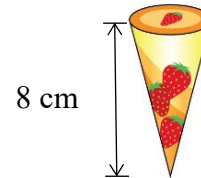

ice cream cone of mini size

Data Handling Strand

21. The following table shows the monthly salaries of 20 employees of Fortune Hypermarket.

Monthly salary (\$)	6 500	8 200	11 700	17 500	26 000
Number of employees	5	4	6	4	1

The mean monthly salary of the 20 employees is

- A. \$16 250.
 B. \$13 980.
 C. \$11 700.
 D. \$11 575.
22. The table below shows the weights of 20 tablets of different models.

Weight (g)	Class boundaries (g)	Class mark (g)	Frequency
301 – 400	300.5 – 400.5	350.5	3
401 – 500	400.5 – 500.5		9
501 – 600		550.5	6
601 – 700	600.5 – 700.5	650.5	2

- (a) Complete the above frequency distribution table.
 (b) Draw a histogram to represent the above data.

23. A teacher conducted a survey on the travelling time spent on going to school of 40 students. The cumulative frequency polygon below shows the result of the survey. Find the median of the travelling time spent on going to school of these 40 students.

Travelling time spent on going to school of 40 students

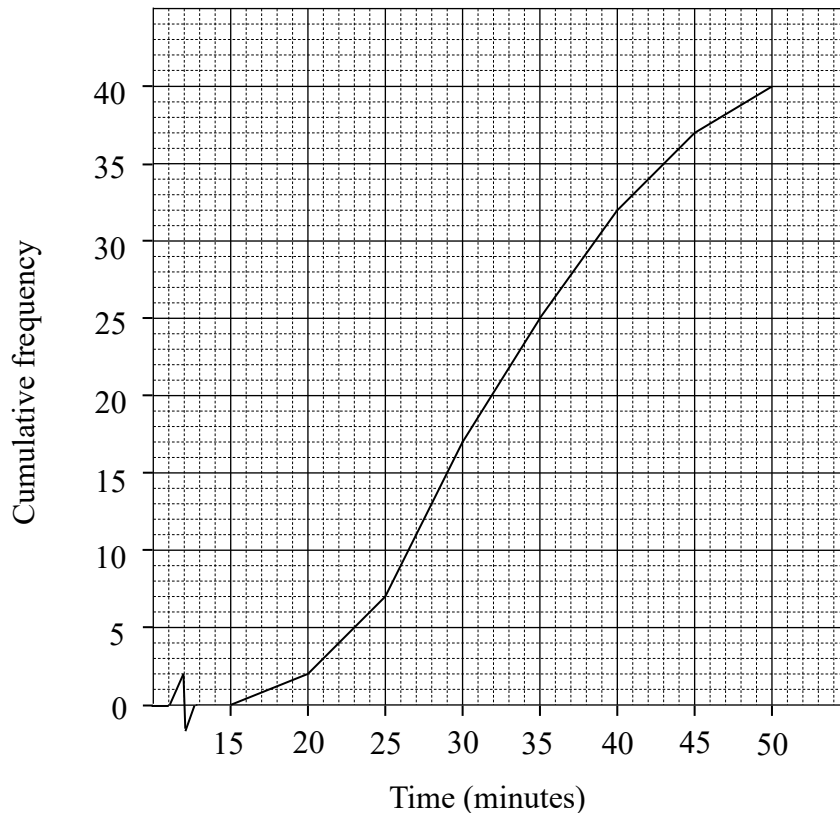

24. There are 120 Form Three students in a secondary school. They need to pay for the student union fee. The table below shows the distribution of their payment methods.

Payment method	Cash	Octopus	Mobile Payment
Number of students	36	61	23

Find the relative frequency of using Mobile Payment as the method of paying student union fee.

Suggested Answers

1. C
2. C
3. A
4. D
5. B
6. (i) +500 dollars
(ii) -20 dollars
7. 36
8. $x \geq 2$
9. The amount that Mr Lee needs to pay = $\$32 \times 21$
= $\$30 \times 20$
= $\$600$

\therefore Mr Lee can enjoy free delivery service.

10. The amount that Jason will receive after 2 years
= $\$25\,000 \times (1 + 6\%)^2$
= $\$28\,090$

11. D
12. 140°

13.

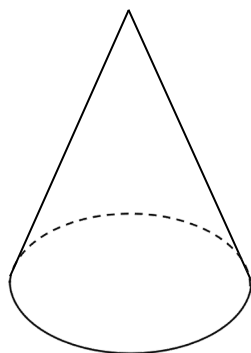

14. B
15. C
16. B
17. 5
18. 25

19. $\angle FGD = \angle CGH = 70^\circ$ (vert. opp. \angle s)
 $\angle EFB = 70^\circ$ (given)
 $\therefore \angle EFB = \angle FGD = 70^\circ$
 $\therefore AB \parallel CD$ (corr. \angle s equal)

20. Let $A \text{ cm}^2$ be the curved surface area of the mini-sized ice cream cone.

$$\frac{A}{208} = \left(\frac{8}{16}\right)^2$$

$$A = 52$$

\therefore The curved surface area of the mini-sized ice cream cone is 52 cm^2 .

21. D

22. (a)

Weight (g)	Class boundaries (g)	Class mark (g)	Frequency
301 – 400	300.5 – 400.5	350.5	3
401 – 500	400.5 – 500.5	450.5	9
501 – 600	500.5 – 600.5	550.5	6
601 – 700	600.5 – 700.5	650.5	2

(b)

Weights of 20 tablets of different models

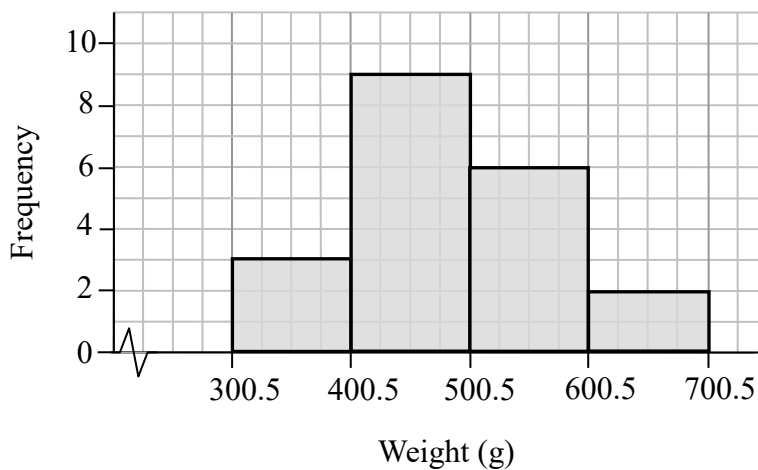

23. 32

24. $\frac{23}{120}$