

2025 年全港性系統評估 (小學) 便覽

**Territory-wide System Assessment 2025
(Primary Schools)
Quick Guide**

第四部分 Part 4

**數學科
Mathematics**

A. Primary 3

1. Scope of the Assessment

The Primary 3 Assessment

- is based on
 - the *Mathematics Education Key Learning Area Curriculum Guide (Primary 1 - Secondary 6) (2017)*; and
 - the *Basic Competency Descriptors for Key Stage 1 Mathematics Curriculum*;
- focuses on the basic and important areas of the Primary 1 to 3 curriculum and assesses the concepts, knowledge, skills and applications in these areas; and
- covers the four strands Number, Measures, Shape & Space and Data Handling.

2. Assessment Design

According to the recommendations given by the Coordinating Committee on Basic Competency Assessment and Assessment Literacy, starting from 2016, the major modifications on assessment papers and question design for Primary 3 Mathematics Assessment are as follows:

- The number of items is reduced by around 20%;
- Only one basic competency is assessed in each item;
- Items requiring solving linking problems are minimized; and
- Items are related to students' life experiences and tied in with their mental development.

3. Format of the Assessment

The Assessment will be conducted in a pen-and-paper mode. In order to cover adequately the areas to be assessed in Key Stage 1, the Assessment will be divided into 4 sub-papers of 40 minutes each. Each student will be required to attempt one of the sub-papers only. Each sub-paper will consist of about 30 items covering the four strands, namely Number, Measures, Shape & Space and Data Handling. Some test items may consist of sub-items.

Sub-paper Strand	Sub-paper 1	Sub-paper 2	Sub-paper 3	Sub-paper 4
Number, Measures, Shape & Space and Data Handling	40 minutes	40 minutes	40 minutes	40 minutes

In the Assessment, various types of items will be used. Some are multiple-choice items, which can be marked objectively. Some are open-ended items, in which students have to fill in the blanks, give their own answers or write mathematical expressions, solutions and explanations.

4. Examples

Some examples are shown below to illustrate the different types of items set. These examples are by no means exhaustive.

Number Strand

1. Three *even numbers* are arranged from the smallest to the largest as shown below.

$$\begin{array}{ccc} 19\,250 & , & \boxed{\quad ? \quad} & , & 20\,138 \\ \text{(Smallest)} & & & & \text{(Largest)} \end{array}$$

The number in the box may be

- A. 18 322
 - B. 19 543
 - C. 19 544
 - D. 20 325
2. $240 + 10 \times 6 = \underline{\hspace{2cm}}$
3. Lily joins a drawing class. The total fee for 3 months is 318 dollars. On average, the fee for one month is
- A. 16 dollars.
 - B. 106 dollars.
 - C. 160 dollars.
 - D. 954 dollars.

4. Mrs Wong makes 8 cakes. $\frac{1}{4}$ of the whole are chocolate cakes and $\frac{1}{8}$ of the whole are banana cakes. The rest are vanilla cakes.



- (a) The number of banana cakes is _____ .

- (b) $\frac{\square}{\square}$ of the whole are vanilla cakes.

5.

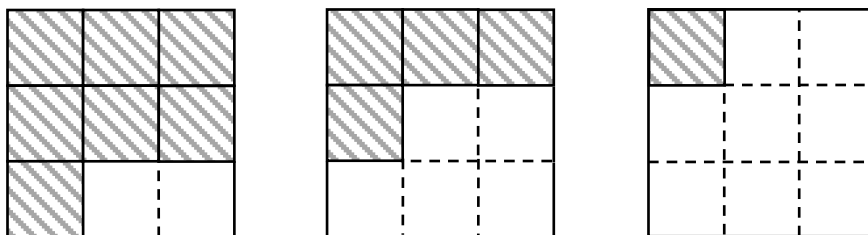

$$\frac{7}{9}$$

–

$$\frac{4}{9}$$

–

$$\frac{1}{9}$$

=

$$\frac{\square}{\square}$$

6. There is a box of batteries on the table. Betty takes $\frac{6}{14}$ of it. Albert takes $\frac{3}{14}$ of it. What fraction of the box of batteries do they take altogether?

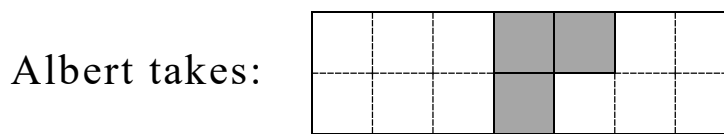
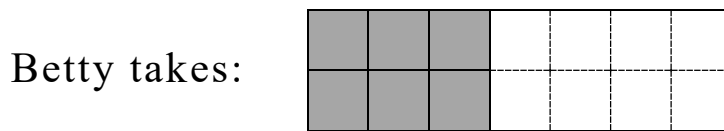

(Show your working)

7.



Teapot
74 dollars



Cup
19 dollars and 90 cents

John buys a teapot and a cup. He should pay

_____ dollars and _____ cents.

Measures Strand

8. The two clocks below show the starting time and the finishing time of a quiz.

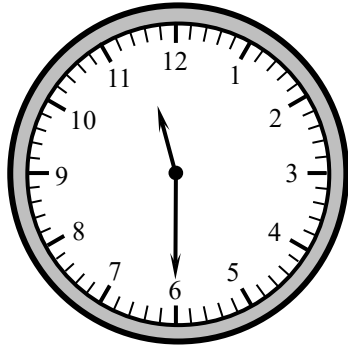

Starting Time

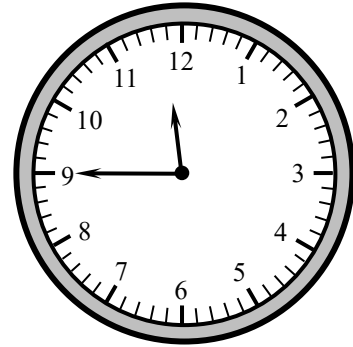

Finishing Time

The time is 11:40 a.m. now.

The quiz has _____ minute(s) left.

9. Use a ruler to measure the length of the toy car below.

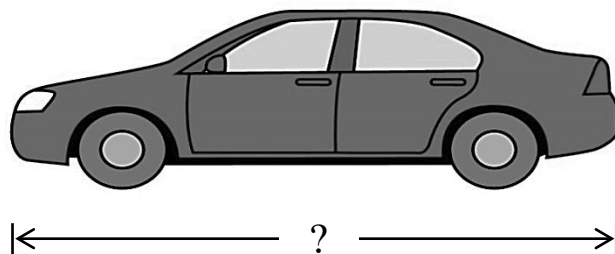

The length of the toy car is _____ cm.

10.

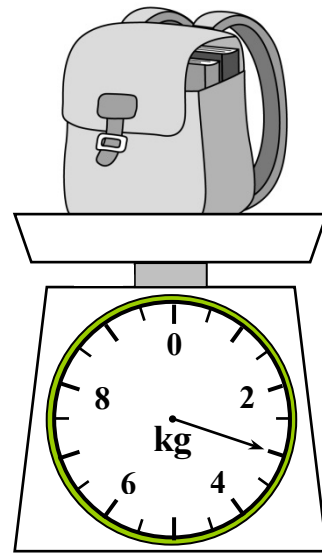
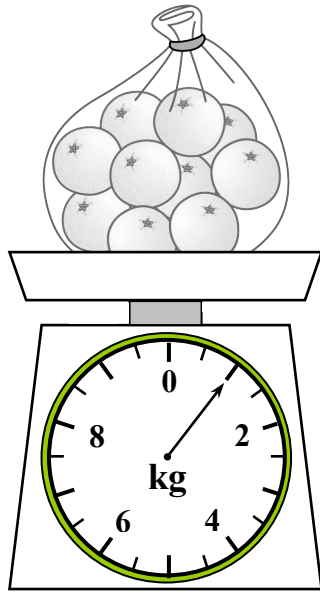

(a) The weight of  is _____ kg.

(b)  is _____ kg * lighter / heavier

than

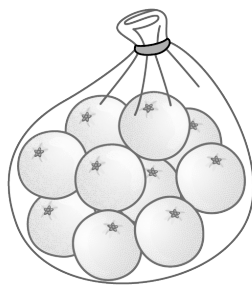

(*Circle the answer)

11. Fill up container **P** with water. Then pour all the water into two empty measuring cups.

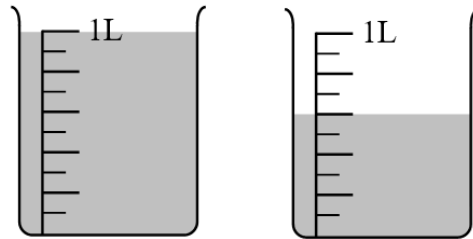
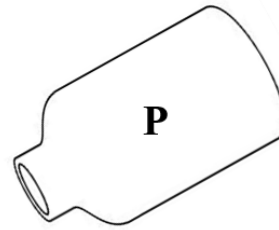

The capacity of container **P** is _____ mL.

Shape & Space Strand

12. Study the following figure. Write down the letters for the answers.

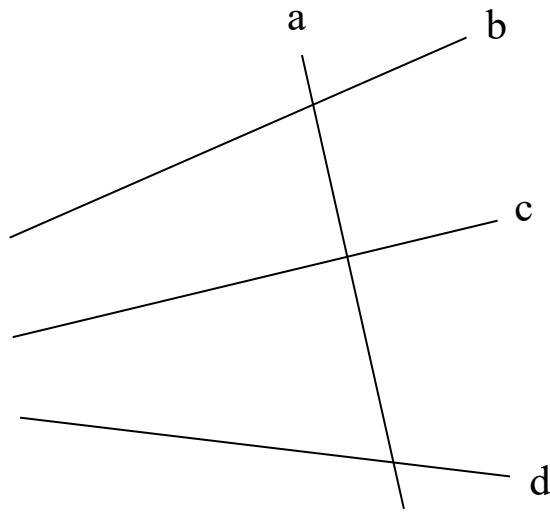

Lines _____ and _____ are a pair of perpendicular lines.

13. Study the following 2-D shapes. Write down all the letters for the answers.

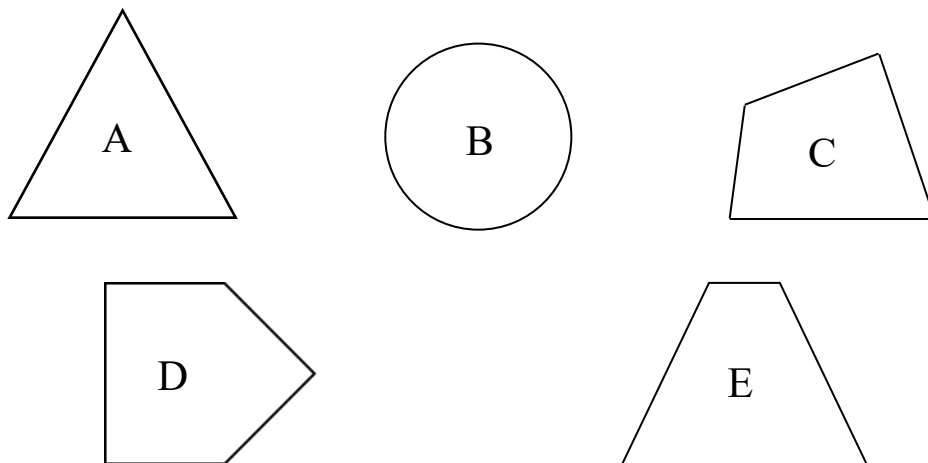

List:

(a) Pentagon(s): _____

(b) Circle(s): _____

14. Study the 3-D shapes below. Write down all the letters for the answers.

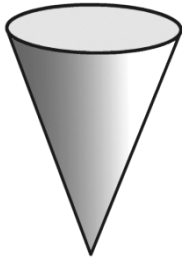

A.

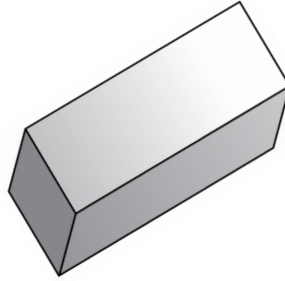

B.

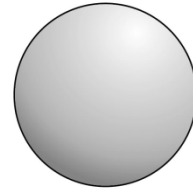

C.

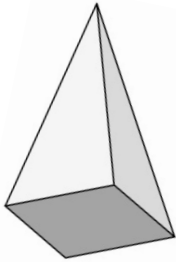

D.



E.

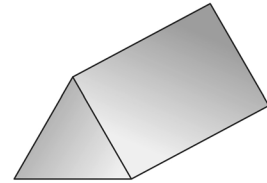

F.

List:

(a) Prism(s): _____

(b) Cone(s): _____

15. The map of a book exhibition is shown below.

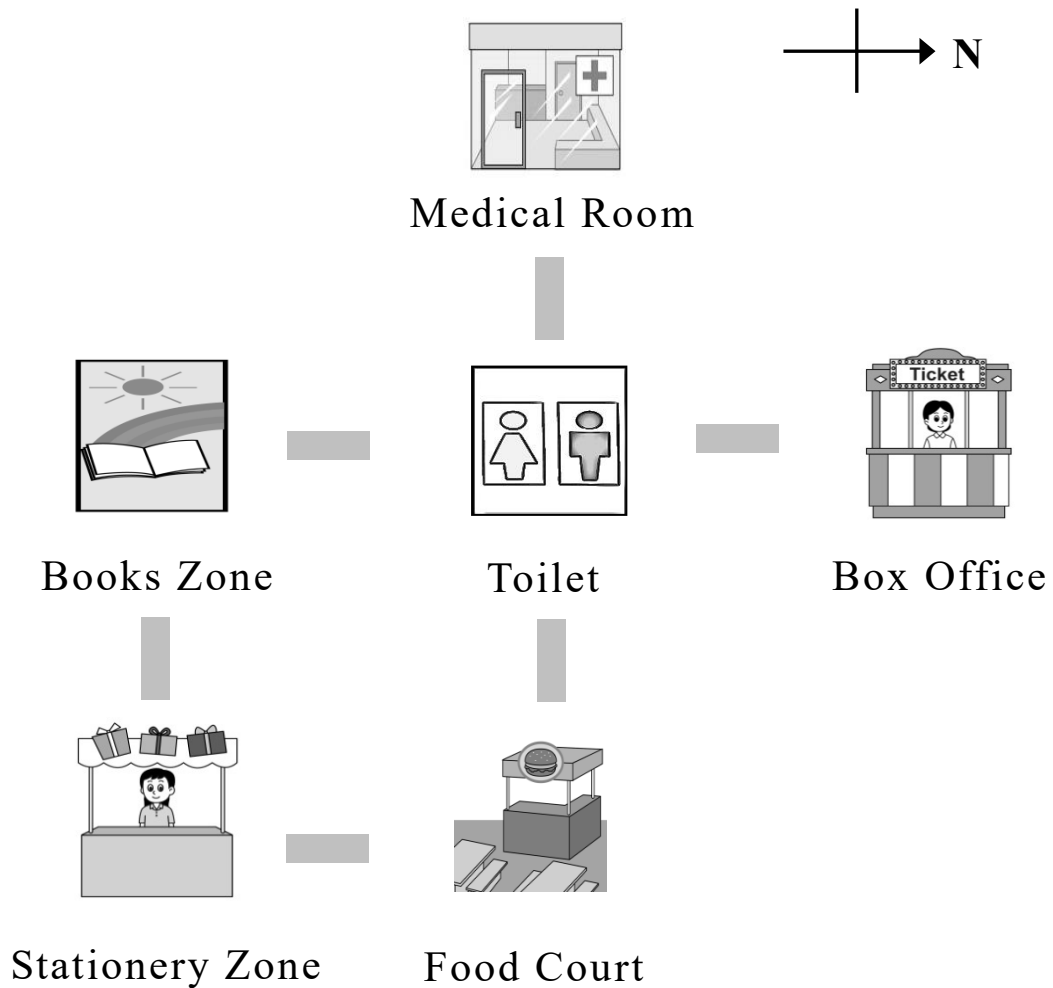

(a) Starting from Toilet, Nancy goes north to reach

* Medical Room / Box Office / Stationery Zone .

(*Circle the answer)

(b) Stationery Zone is to the

* east / south / west / north of Food Court.

(*Circle the answer)

Data Handling Strand

16. Mr Ng did a survey of the favourite snacks of P.3C pupils.

Favourite Snacks of P.3C Pupils

Each ☺ stands for 1 pupil

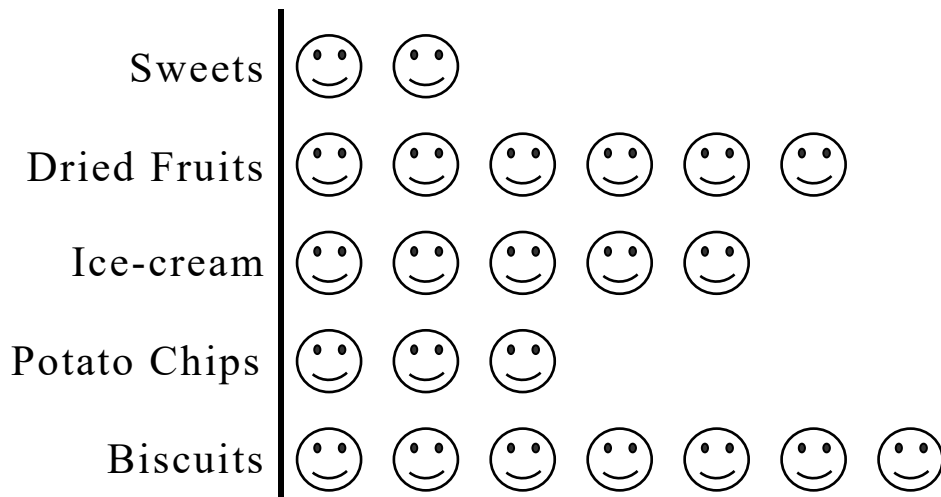

- (a) The number of pupils who favoured ice-cream was _____ .
- (b) The number of pupils who favoured dried fruits was _____ * more / less than that of pupils who favoured sweets.

(*Circle the answer)

17. The following bar chart shows the number of pupils in each Primary Three classes visiting the library yesterday.

Number of Pupils in Each Primary Three Classes Visiting the Library Yesterday

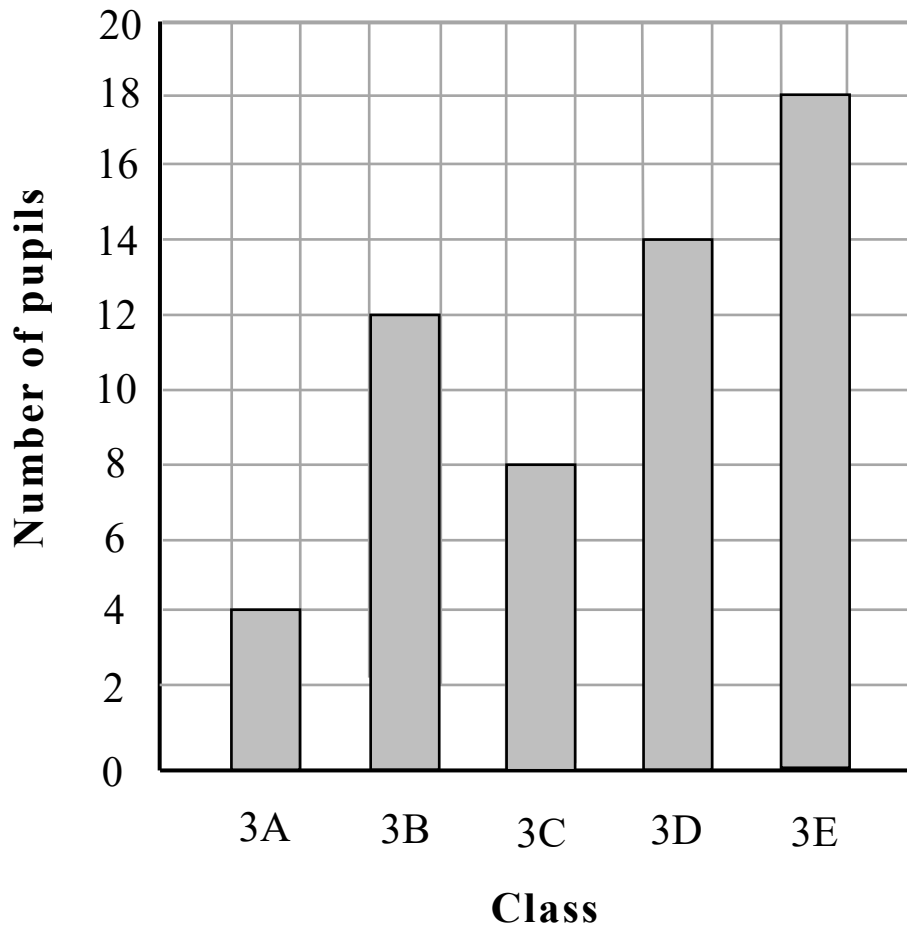

- (a) The number of pupils in Class _____ visiting the library yesterday was the least. There were only _____ pupils.
- (b) The total number of Primary Three pupils visiting the library yesterday was _____ .

Suggested Answers

1. C

2. 300

3. B

4. (a) 1

(b) $\frac{5}{8}$

5. $\frac{2}{9}$

6. $\frac{6}{14} + \frac{3}{14}$
 $= \frac{9}{14}$

They take $\frac{9}{14}$ box of batteries altogether.

7. 93, 90 respectively

8. 5

9. 8

10. (a) 3

(b) 2, circle 'heavier' respectively

11. 1 600

12. a, c / c, a

13. (a) D
(b) B
14. (a) B, F
(b) A
15. (a) Circle 'Box Office'
(b) Circle 'south'
16. (a) 5
(b) 4, circle 'more' respectively
17. (a) 3A, 4 respectively
(b) 56

Remark: Answers with incorrect spelling may not be accepted if mathematical terms (including the names of 2-D or 3-D shapes, names or symbols of measurement units, and the four directions) are involved.

B. Primary 6

1. Scope of the Assessment

The Primary 6 Assessment

- assumes pupils already have mastered the Basic Competencies covered in Key Stage 1;
- is based on
 - the *Mathematics Education Key Learning Area Curriculum Guide (Primary 1 – Secondary 6) (2017)*; and
 - the *Basic Competency Descriptors for Key Stage 2 Mathematics Curriculum*;
- focuses on the basic and important areas of the Primary 4 to 6 curriculum and assesses the concepts, knowledge, skills and applications in these areas;
- covers the five strands Number, Measures, Shape & Space, Data Handling and Algebra; and
- will not specifically assess all the Basic Competencies covered in Key Stage 1, but relevant knowledge and skills may be required to answer the items set in this Assessment.

2. Format of the Assessment

The Assessment will be conducted in a paper-and-pencil mode. In order to cover adequately the areas to be assessed in Key Stage 2, the Assessment will be divided into 4 sub-papers of 50 minutes each. Each pupil will be required to attempt one of the sub-papers only. Each sub-paper consists of about 40 test items covering the five strands Number, Measures, Shape & Space, Data Handling and Algebra. Some test items may consist of sub-items.

Sub-paper Strand	Sub-paper 1	Sub-paper 2	Sub-paper 3	Sub-paper 4
Number, Measures, Shape & Space, Data Handling and Algebra	50 minutes	50 minutes	50 minutes	50 minutes

In the Assessment, various types of test items will be used. Some are multiple-choice items which can be marked objectively. Some are open-ended items, in which pupils have to fill in the blanks, give their own answers or write mathematical expressions, equations, solutions and explanations.

3. Examples

Some examples are shown below to illustrate the different types of items set. These examples are by no means exhaustive.

Number Strand

- Which of the following numbers are prime numbers?

(Circle all the answers)

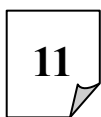

- List all the common factors of 18 and 24.

Answer: _____

3. Arrange the following numbers from the largest to the smallest.

$$1\frac{1}{3} \quad , \quad 2 \quad , \quad \frac{5}{6}$$

Answer: , ,
(Largest) (Smallest)

4. $30 + 520 \div 5 =$

- A. 44
- B. 104
- C. 110
- D. 134

5. $\frac{5}{6} \div (4 - 1\frac{2}{3}) =$

6. Each piece of cake costs 10.8 dollars. Mr Chan pays with a 100-dollar note for 4 pieces of cake. He gets _____ dollar(s) change.

7. There are 20 cartons of drinks on the table. 40% of them are juice. 25% of them are milk. How many cartons of juice and milk are there altogether?

(Show your working)

8. A pencil costs 8.9 dollars and Stella has 102 dollars. Which of the following expressions is most suitable for estimating the number of pencils she can buy at most?

- A. $110 \div 9$
- B. $100 \div 9$
- C. $110 \div 8$
- D. $100 \div 8$

Measures Strand

9. A birthday party started at 11:20 a.m. and ended at 2:35 p.m. The birthday party lasted for _____ hour(s) and _____ minute(s).

10. In the following diagram, the side of each square is 1 cm.

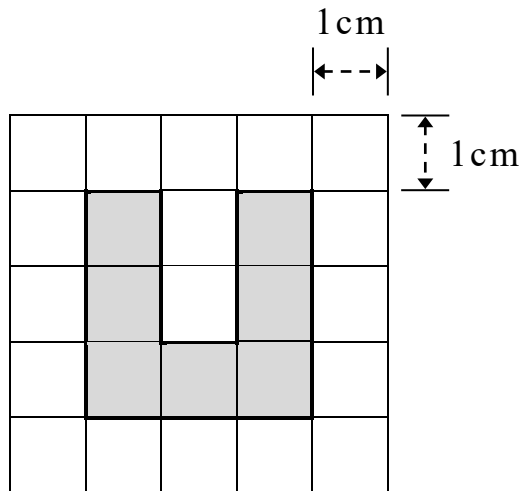

The perimeter of the shaded part is _____ cm.

- 11.

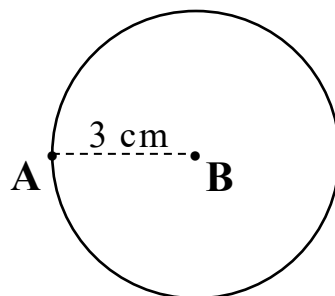

In the figure above, Point **B** is the centre of the circle.

AB is 3 cm long. The area of the circle is _____ cm^2 .

(Take π as 3.14)

12.

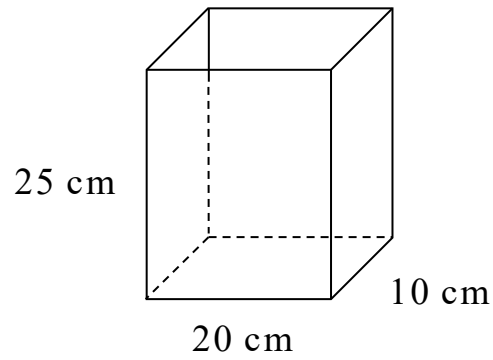

The capacity of the rectangular container above
is _____ L.

13. Measure $\angle a$ below with a protractor.

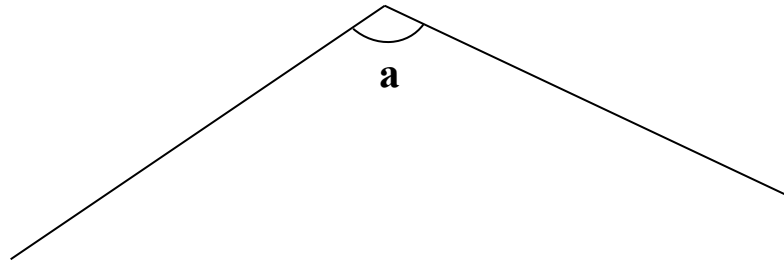

$\angle a =$ _____

(Give the answer with a unit)

Shape & Space Strand

14.

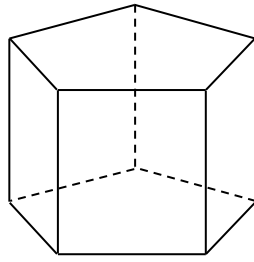

The prism above has _____ vertices and
_____ edges.

15.

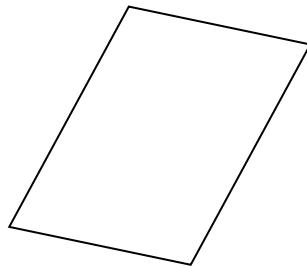

The figure above is a

* parallelogram / rectangle / rhombus .

(*Circle the answer)

It has _____ pair(s) of opposite sides parallel.

16.

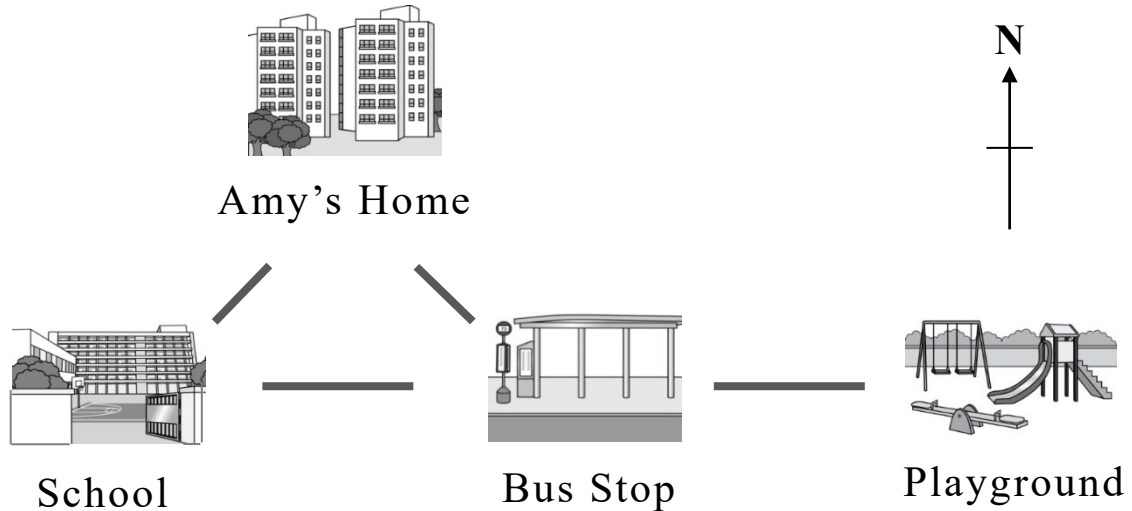

(a) Amy goes home from Bus Stop. She should walk towards _____.
(direction)

(b) _____ is to the east of Bus Stop.

17. Study the 2-D shapes below. Write all the letter(s) for the answer.

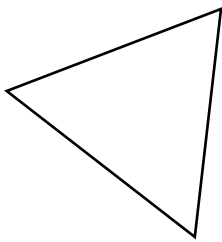

A

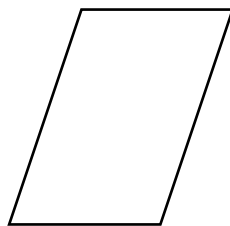

B



C

List the axially symmetric shape(s).

Answer: _____

Data Handling Strand

18. The weights of Tom, May and Peter are 62 kg, 40 kg and 54 kg respectively. Their average weight is _____ kg.
19. The following pie chart shows the sales of four kinds of snacks at Tasty House yesterday. The total sales of the four kinds of snacks are 120 packs.

**Sales of Four Kinds of Snacks
at Tasty House Yesterday**

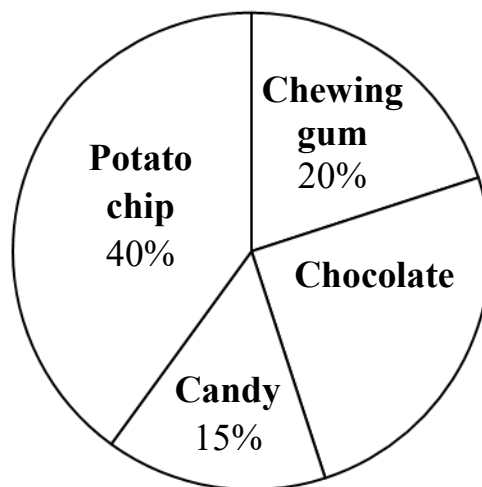

- (a) The sales of chocolate is _____% of the total sales of the four kinds of snacks.
- (b) The sales of _____ were the most.
_____ packs were sold.

20. The table below shows the number of soft drink cans recycled by a school from March to July.

Month	March	April	May	June	July
Number of soft drink cans	90	120	160	240	100

According to the information above, complete the broken line graph below and give it a title.

(Title)

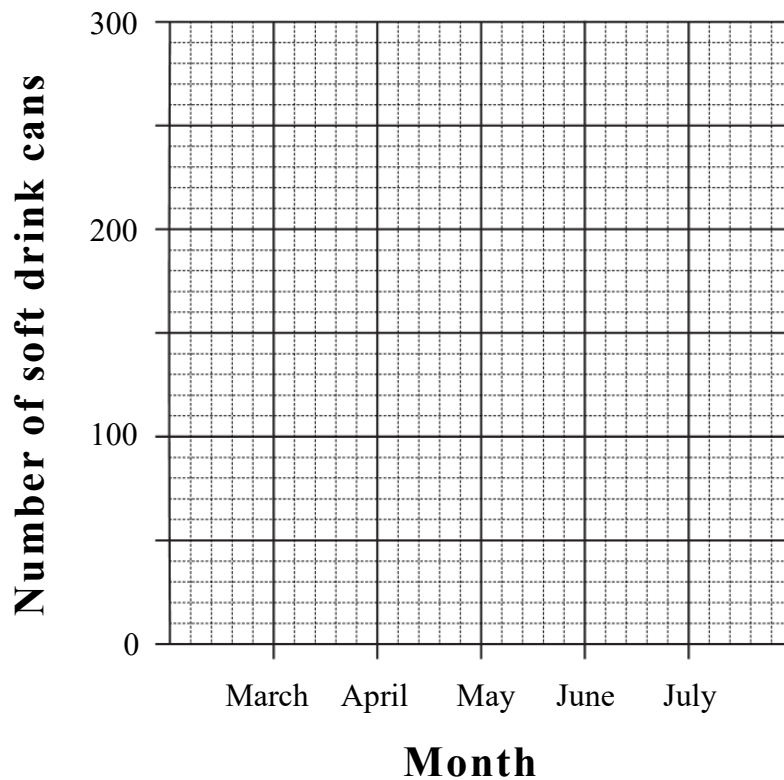

Algebra Strand

21. Tim has 30 dollars. Betty has x dollars more than Tim.
How many dollars do they have altogether?

- A. $30 + x$
- B. $60 + x$
- C. $60 - x$
- D. $30x$

22. $2y - 10 = 8$

$y =$

23. Mr Chan bought 1 hot dog and 4 hamburgers. He paid 57 dollars altogether. The price of each hot dog was 9 dollars. Find the price of each hamburger by *the method of solving an equation*.

(Show your working)

Suggested Answers

1. Circle '11', '89'
2. 1, 2, 3, 6
3. 2 , $1\frac{1}{3}$, $\frac{5}{6}$ respectively
4. D
5. $\frac{5}{14}$
6. 56.8
7. $20 \times (40\% + 25\%)$
 $= 13$
There are 13 cartons of juice and milk altogether.
8. B
9. 3, 15 respectively
10. 16
11. 28.26
12. 5
13. 120°
14. 10, 15 respectively
15. Circle 'parallelogram', 2 respectively
16. (a) north-west/ NW
(b) Playground
17. A, C
18. 52
19. (a) 25
(b) potato chips, 48 respectively

20. (a) Title: Number of soft drink cans recycled by a school from March to July

(b)

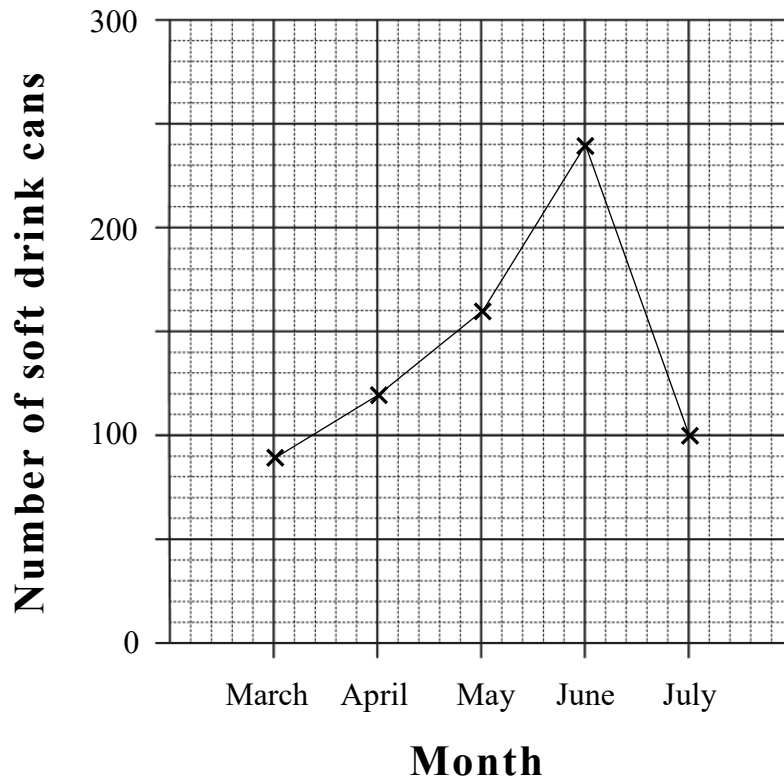

21. B

22. 9

23. Let the price of each hamburger be x dollars.

$$9 + 4x = 57$$

$$4x = 48$$

$$x = 12$$

The price of each hamburger is 12 dollars.

Remark: Wrong spellings and incorrect Chinese characters may not be accepted as correct answers if mathematical terms (including the names of 2-D or 3-D shapes, names or symbols of measurement units and the eight compass points) are involved.